



CURRENT SENSOR DRYER AMP SENSOR FAN CONTROL

PRODUCT
SPECIFICATIONS
AND ENGINEERING
INFORMATION
SUBMITTAL DATA
847-6-03

This controller senses when a clothes dryer is drawing 1 amp of current. When this occurs a relay contact closes turning on the dryer vent booster fan. When current drops below threshold the relay contacts open turning off the fan. The 1 amp current threshold specification may be modified if necessary. The sensor is rated to control a load of 2.5 Amps at 115 V. For higher amperage loads, a general purpose relay may be used to control the load.

The sensor is designed to mount in a standard electrical box. The current transformer may be placed in an electrical box adjacent to the junction box in which the wires supplying power to the dryer are located. The dryer supply neutral (white) wire passes through the center of the

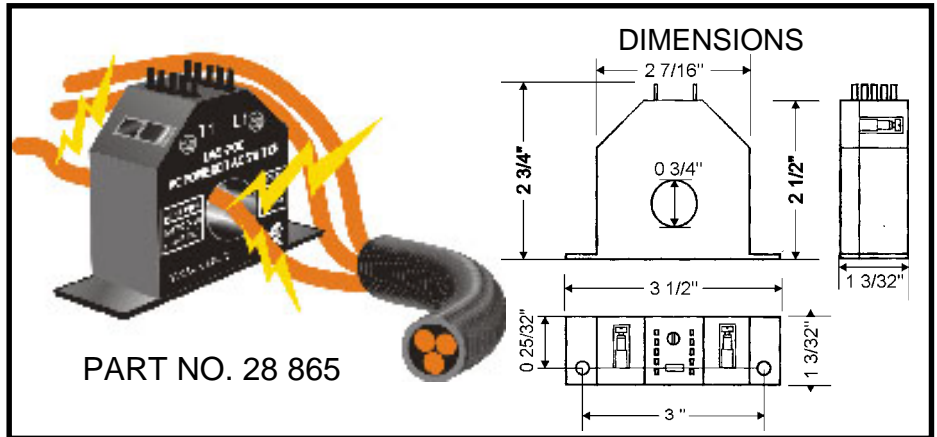

current transformer donut. No physical connection need be made.

NOTE: Installation by a licensed electrician is recommended. Installation and use of this equipment must

be in accordance with provisions of the national electrical code. Applicable local codes and pertinent industry standards should be verified before installation.

Installation Type 1 (at dryer junction box)

1. Attach electrical junction box to the dryer junction box.
2. Disconnect and loop neutral (white) dryer power supply wire through center of sensor then back to the dryer junction box and reconnect.
3. Mount sensor in the electrical box (two holes may have to be drilled for mounting).
4. Connect fan 120V AC power supply to the top (relay) terminals of the sensor.

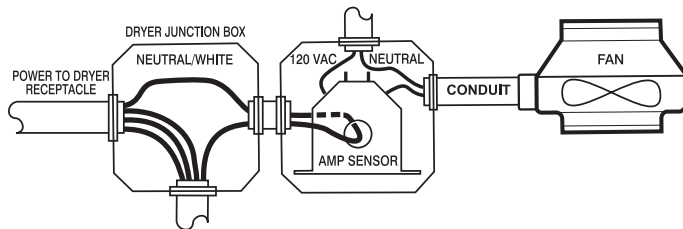

Installation Type 2 (at fuse/breaker panel)

1. Mount sensor at a convenient location on the fuse/breaker panel.
2. Disconnect and loop neutral (white) dryer power supply wire through center of sensor then reconnect.
3. Connect fan 120V AC power supply to the top (relay) terminals of the sensor.

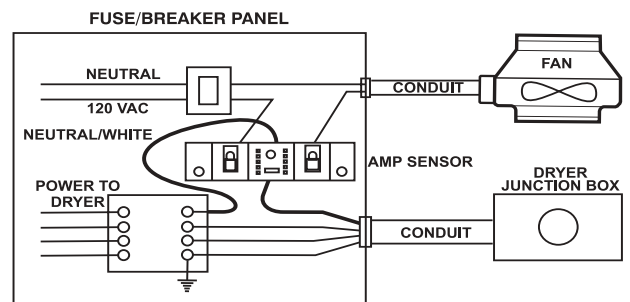

BY MATHEWS GRAPHIC DESIGN



PROJECT	DATE	SUBMITTED BY	CONTRACTOR
---------	------	--------------	------------



4537 NORTHGATE COURT
SARASOTA, FL 34234-2124, USA
Tel: 941 • 351- 3441
Fax: 941 • 351- 3442
www.aldes-us.com
e-mail: info@aldes-us.com

