



HRV 2000SFDE HEAT RECOVERY VENTILATOR

PRODUCT
SPECIFICATIONS
AND TECHNICAL
DATA

1437-7-06

SPECIFICATIONS

AIRFLOW

2000 cfm (940 L/s) at 1.0"wg ESP.

PERFORMANCE

65% effective at 2000 cfm (940 L/s).

CORES

Eight patented aluminum heat recovery cores arranged for efficient cross-flow ventilation.

MOTORS

Two single speed, single shaft, 208-240VAC, 8.0 Amps, (16.0 TOTAL), 1.5 hp.

BLOWERS

Two belt drive centrifugal blowers with adjustable pulleys, one per airstream.

FILTERS

Two - 16" x 25" x 2" pleated filters in each airstream.
MERV 6 efficiency 60% @ 4.69 microns.

DUCT CONNECTIONS

Two 20" x 19" hoods included with washable screens.
Two 25" x 16" connections to and from building under cabinet.

CABINET

20 gauge powder coated steel exterior. Unit includes metal lined sides and roof panels with 2" fiberglass insulation (R8) between linings.

DRAIN

Two powder coated galvanized steel drain pans with 1/2" O.D. drain connections.

MOUNTING

Optional roof curb. (Part No. 28 129)

CONTROLS & FUNCTION

Integrated microprocessor circuit board.

DEFROST

Factory set defrost time. Supply motor is shut off while exhaust air defrosts core.

WEIGHT 750 lbs (340 kg)

SHIPPING WEIGHT 800 lbs (363 kg)

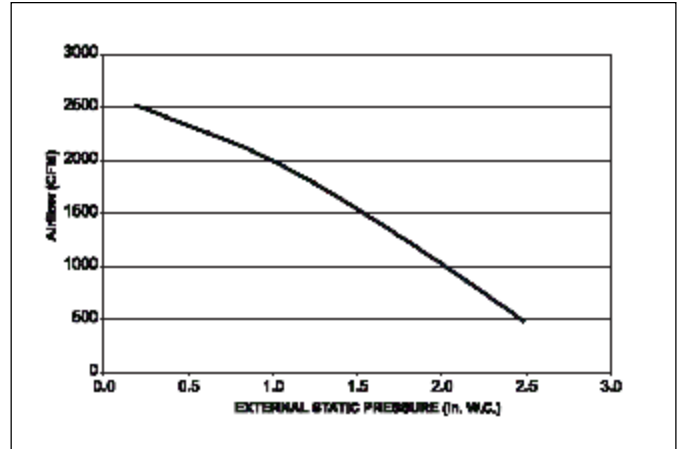

OPTIONS

28 879 Digital Electronic Timer - 20/40/60 min. (3 wire)

28 883 Dehumidistat Ventilation Control (DVC)

28 882 Remote Wall Mount Dehumidistat Control

24 VAC only

28 99500 3 Speed Control

All units conform to CSA and UL standards

WARRANTY

All units carry a 15 year warranty on the heat recovery cores and a 2 year replacement parts warranty.

DIMENSIONS 2000SFDE (inches)

	A	B	C	D	E	F	G	H	I	J	K	L	M
2000SFDE	24	3	19	14.75	43	69.5	24	19	13.75	3	20	57.25	59.75

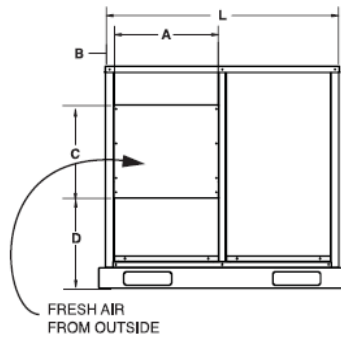

INLET END VIEW

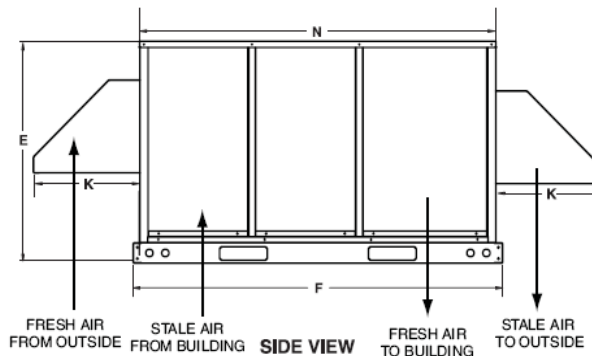

SIDE VIEW

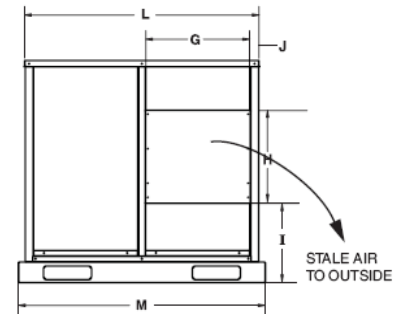

OUTLET END VIEW

Service Clearance 30"

MATHEWS GRAPHIC DESIGN - 941-358-0862



AMERICAN ALDES
VENTILATION CORPORATION
4537 NORTHGATE COURT
SARASOTA, FL 34234-2124
Tel: 941 • 351-3441
Fax: 941 • 351-3442
www.americanaldes.com
e-mail: info@aldes-us.com

IAQ
VENTILATION
HOTLINE
800-255-7749
ALDES

1437-7-06