

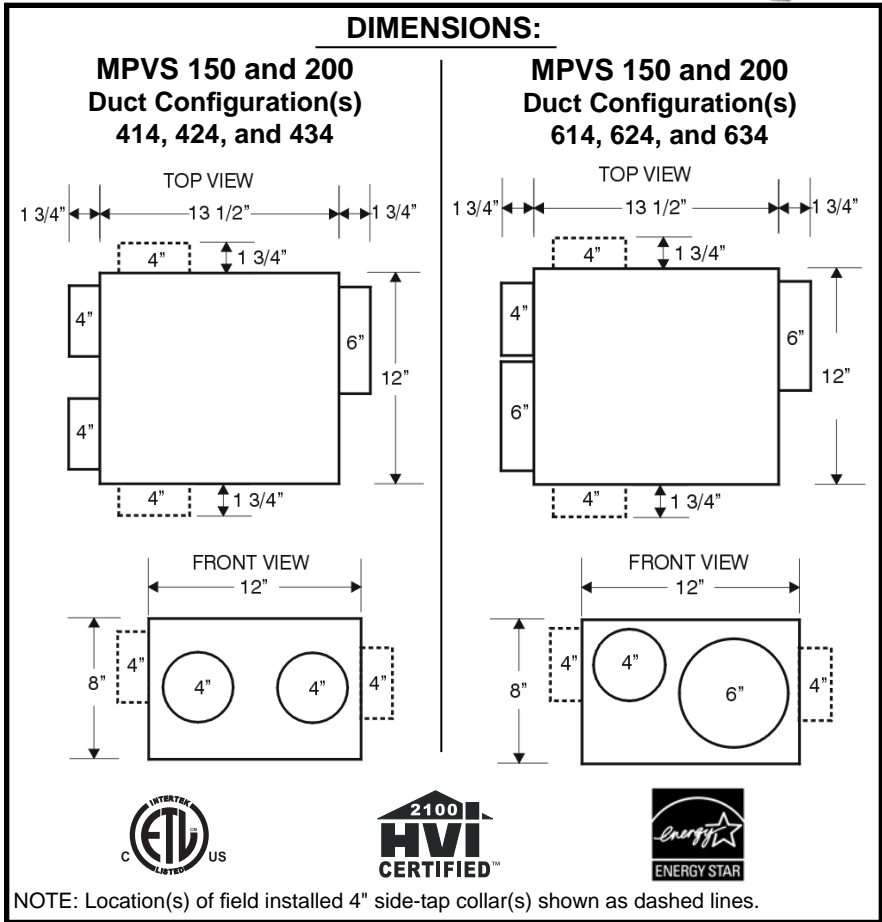
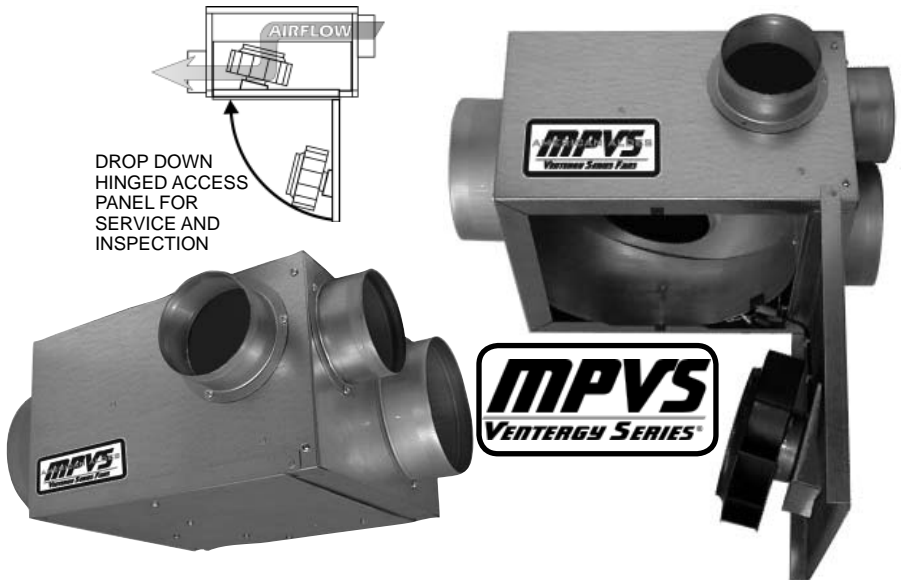
**General:** MPVS Series Multi-Port ventilators are highly versatile continuous duty rated fan units for residential and light commercial applications, and meet ENERGY STAR efficiency criteria for low energy consumption. The most popular use for the fan is central exhaust ventilation of bathrooms, kitchens, laundry rooms, and other rooms where humidity is a controlling factor, since the fan has a single exhaust discharge duct directly to the outdoors.

The principle advantage of the MPVS central exhaust system is the elimination of standard noisy bath fans, with the obvious benefits of quiet operation and reduced penetrations to the exterior of the building. In addition, with the increased tightness of construction for energy efficient buildings, there is a growing need of mechanical ventilation for indoor air quality. These fans are designed to serve this purpose as well, by providing effective bathroom ventilation, with the ability to run intermittently or continuously as needed. The quiet, energy efficient permanent split capacitor external rotor motor has permanently sealed bearings that provide many years of maintenance-free performance.

**Construction:** The MPVS fan is constructed of heavy gauge galvanized steel to prevent corrosion caused by moisture. The cabinet is internally lined with UL rated, acoustic closed-cell foam vapor barrier insulation. This allows installation directly above living spaces, or in unheated plenum spaces without concern for noise or condensation.

**Fan and Motor:** The fan motor is an energy efficient permanent split capacitor type, of external rotor design. Totally sealed to protect against moisture and contaminants, it is approved for use to remove steam and moisture in kitchen and bath areas. The motor incorporates permanently lubricated sealed bearings and automatic reset thermal overload protection. It is designed and certified for continuous duty or intermittent operation.

The fan uses a backward inclined impeller design that minimizes dust from collecting on the blades and affecting airflow performance. Each fan is statically and dynamically balanced in the factory to eliminate vibration and ensure quiet operation. The entire motor and fan assembly is mounted on a drop-down hinged access panel for service and inspection, and can be removed from



<b>ELECTRICAL AND AIRFLOW PERFORMANCE*</b>										
Model	Nominal RPM	HP	Watts at .2" Ps	MAX. AMPS	CFM vs. Static Pressure					
					0"	.2"	.4"	.6"	.8"	1.0"
MPVS-150	2200	0.06	41	.34	211	171	134	102	72	45
MPVS-200	2960	0.08	63	.53	276	251	224	197	171	145

\*Certified airflow rating at 0.2" w.g. is derated from actual test results per HVI Certification procedure 920.

the fan without disassembly of the ducting connections.

**Controls:** The fans can be operated manually, or automatically by a programmable timer or dehumidistat and may also be operated in conjunction with a variable speed control.

**Locating and Installing the Fan:** The compact dimensions and versatile mounting options permit installation above drop ceilings, between ceiling joists, or within a small soffit location. The fan can be installed either horizontally or vertically.

**Airflow Balancing:** The flow rates can be set with either manually adjustable grilles, such as the ALGRILLES in the standard kit of accessories, or with preset ALDES Constant Airflow Regulators, used with fixed grilles with large free area as in the deluxe kit.

**Standard Accessory Kit Option:** Each standard accessory kit includes round adjustable grilles constructed of heavy duty moisture resistant plastic. Also included are corresponding ceiling sleeves with integral energy saving back draft dampers that protect against drafts and risk of condensation in the duct when the MPVS is not being used.

**Deluxe Accessory Kit Option:** To ensure balanced exhaust points independent of duct lengths, the deluxe accessory kit includes constant airflow regulators at each point. A passively controlled element in each duct run inflates or deflates automatically in response to system pressure to maintain constant airflow. Also included are fixed Deco grilles constructed of heavy-duty moisture resistant plastic. Standard ceiling sleeves with integral energy saving back draft dampers are also included.

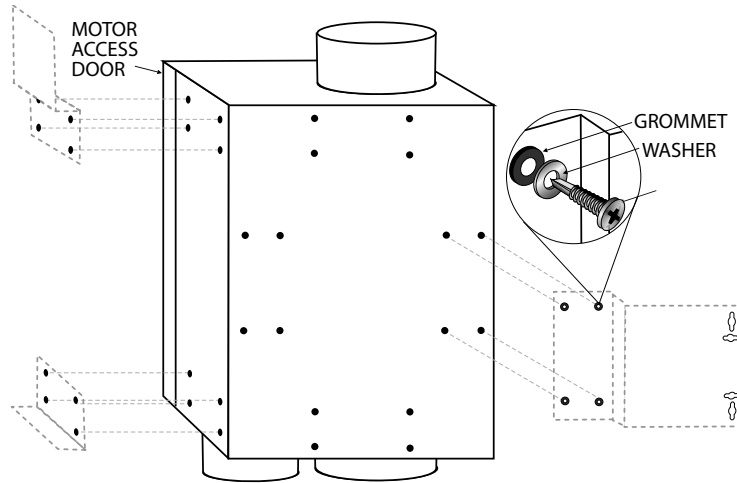
**ELECTRICAL DATA**

**MPVS 150 / 200:**  
120 V, 60 Hz., .34/.53 amp., 41/63 W Max.,  
2200/2960 RPM

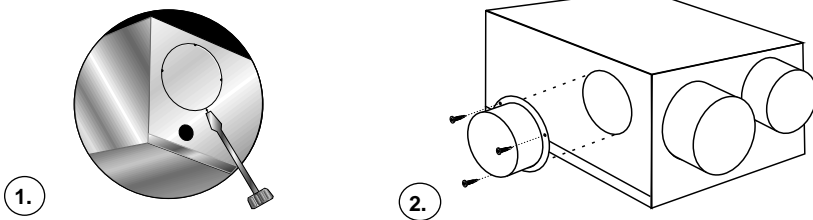
*Above ratings are intended for sizing electrical wiring only.  
Actual consumption will be lower.*

## Mounting Bracket Locations

Small dimples or "scratches" are machined on the fan housing to aid in using the #8-3/4" self-tapping screws (provided) for mounting bracket installation. The locations are represented in the below diagram. To prevent potential damage to internal parts, DO NOT use screws or washers other than those provided. Use four screws and washers for each bracket.



Additional four-inch collar(s) may be provided for field installation depending on your specific model. Collars are installed on the side(s) of the base MPVS at the knock-out locations as indicated below. (1) Remove the metal knock-out using a slot-type screw driver or similar tool -1 firm hit to holding tabs. The liner applied to the inside of the knock-out should break away from the fan liner, but additional trimming with a sharp knife may also be required - pull out from the inside of box. (2) Attach the collar(s) provided using #8-1/2" screws (also provided).



**TABLE OF AIRFLOWS AND DUCT LENGTHS\***

AIRFLOW CFM	INTAKE DUCT TO FAN Recommended Max. Duct Length from Grille to Fan (ft.)			
	4" SMOOTH	4" FLEXIBLE	6" SMOOTH	6" FLEXIBLE
50	50	30	400	250
60	40	20	280	175
80	-	-	170	95
100	-	-	110	70

TOTAL EXHAUST RATE CFM	FAN DISCHARGE DUCT Assumes low pressure drop vent cap		FOR EACH ELBOW DEDUCT
	6" SMOOTH	6" FLEXIBLE	
175	20 ft	10 ft	4" Diameter - 4.0 ft. 6" Diameter - 7.0 ft.
200	15 ft	8 ft	
225	13 ft	7 ft	

\*This table should only be used as a general guide. Actual duct length allowances may be longer on some models. Contact the factory for assistance. NOTE: 3" Ducting may be substituted to permit installation in partition walls. Smaller diameter ducting has increased resistance to airflow. For each foot of 3" ducting substituted for 4" diameter duct, reduce the allowable duct length by 3 feet. If longer duct runs are required than permitted in the table above, use smooth ducting and/or increase the diameter.



4521 19th Street Court E., Suite 104, Bradenton, FL 34203 USA  
P: 941-351- 3441 - F: 941-351- 3442  
www.americandaldes.com ~ E: info@aldes-us.com



mpvs\_150\_200\_iom\_0510

**READ AND SAVE THESE INSTRUCTIONS**

**For The Following Base Models:**

**RDF 8-8IP, RDF 8-8MAX, RDF 12-8IP, RDF 12-8**

*(See supplemental instructions for derived models, with duct adapters, manifolds, etc., as appropriate for your particular model.)*

**CAUTION**

**For General Ventilating Use Only. Do Not Use to Exhaust Hazardous or Explosive Materials and Vapors.**

**WARNING**

**TO REDUCE THE RISK OF FIRE, ELECTRIC SHOCK, OR INJURY TO PERSONS, OBSERVE THE FOLLOWING:**

- A. Use this unit only in the manner intended by the manufacturer. If you have any questions, contact the manufacturer.
- B. Before servicing or cleaning unit, switch power off at service panel and lock service panel to prevent power from being switched on accidentally. When the service disconnecting means cannot be locked, securely fasten a prominent warning device, such as a tag to the service panel.

In addition to the following manufacturer's instructions, it is necessary to comply with federal, state, and local government codes. Your purchase of this American ALDES ventilation system represents an investment in the health and comfort of the occupants, as well as an investment in the protection of the building from the damaging effects of excessive indoor humidity.

This model of centrifugal fan is designed for multiple purposes. It may be used as an in-line rectangular duct fan (Model RDF) or a manifolded, multi-port fan for multiple exhaust or supply points. It may be installed in a remote location such as an attic space, mechanical room or above a drop ceiling, in a closet or laundry room, to provide quiet exhaust of stale, humid, or otherwise polluted air from bathrooms, the kitchen, laundry, or storage rooms, via exhaust grilles and ducting to the centrally located fan, which is ducted to the outdoors. With small return grilles in bedrooms and other areas, and one duct connection

to the outdoors, as the BVS models, it may also be used as a supply ventilator or recirculating central ventilator for the introduction of outdoor air, raising the temperature of the fresh air by mixing with recirculated indoor air. When used with adjustable balancing grilles or ALDES CAR, Constant Airflow Regulators, and compatible roof/wall caps, ducting, etc., the fan is the heart of a complete pre-engineered ventilation system.

**SYSTEM DESIGN:**

Satisfactory performance of a central ventilation system requires the proper integration of all the components:

- Fan selection for airflow, pressure and acoustic properties, vibration characteristics and mounting method, and mode of operation (continuous, manually or automatically controlled)
- Proper duct design for friction losses, with compatible supply or exhaust grilles (airflow and acoustic properties of the supply/exhaust grilles, and compatible wall/roof caps)
- Method of balancing airflows of multi-point ventilation systems
- Consideration for the potential of condensation in the ducting or fan housing (installation in an unheated space)

Upon receipt, inspect the carton to insure the fan has not been damaged in transit. If damaged, it is the responsibility of the recipient to file a damage claim with the carrier. American ALDES Ventilation Corporation is not responsible for damage incurred during shipment.

Handle the unit with care to prevent damage to the housing and other components. Store the unit indoors if possible. If outdoor storage is required, protection against moisture and dirt is necessary.

Unpack the unit, taking care to look for any loose components among the packing material. Make certain that the fan housing and the blower is free of any loose packing material or small parts. If not removed before startup, damage and injury may result from solid objects discharged by the blower. Inspect for damage, loose or missing parts.

Install the unit in its final location. The fan may be installed in a mechanical room, crawl space or attic. It is designed to be placed on a flat surface, against a wall or trusses, or suspended from above. If set on a flat surface, vibration isolation pads are recommended. Mounting brackets with rubber grommets are supplied to permit installation against a vertical surface or from a ceiling above. Alternatively, it may be suspended using threaded rods or chains. At least 12 inches clearance is needed from the access panel to permit servicing the motor.

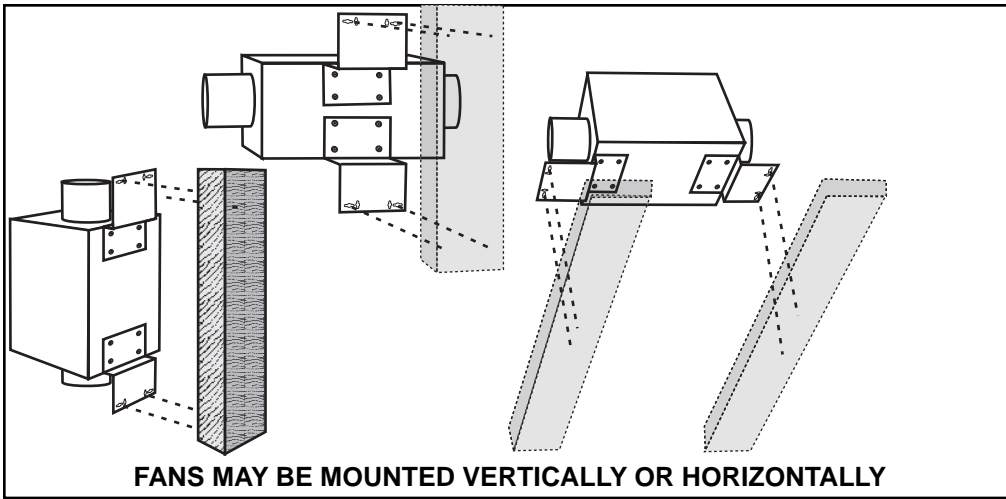
**MOUNTING INSTRUCTIONS**

(Differences in bracket type and configuration may exist on some derived models. Refer to supplement where appropriate). Orient the fan so that the access door can be opened for service.

**Tools Required:**

**Power screwdriver with No. 2 Philips bit.**

Mounting brackets are supplied with the fan. The brackets may be mounted to the fan using the self-drilling screws and rubber grommets provided, at the locations indicated by dimple marks on the side and bottom panels of the fan. Pan head number 10 screws are provided to attach the mounting bracket to the building framing members. It may be necessary to add additional framing members to span wall studs. It is not recommended to use drywall anchors to support the fan. If installed against a concrete or masonry wall, concrete



**FANS MAY BE MOUNTED VERTICALLY OR HORIZONTALLY**

anchors are recommended. The rubber grommets provide vibration isolation.

The brackets should be attached to the fan first. Then install the wood screws at the keyhole locations and install the fan.

The fan may also be mounted on a foam rubber pad on a flat surface, such as an attic floor.

**COLD CLIMATE PRECAUTIONS**

If installed in an unheated space, in cold climates, there is a possibility

of condensation forming in the fan housing or ducting components. A backdraft damper installed at each grille is very effective in reducing the potential for condensation when the fan is cycled on and off. Insulated ducting must be used where exposed to cold attic or crawl space temperatures, to avoid condensation in the ducting. Condensation can also be avoided by continuous operation of the fan.

**DUCT CONNECTIONS**

Ducting may be flexible or rigid,

depending on local codes. If permitted by code, insulated flexible ducting is recommended for at least several feet on each duct connection, to limit fan noise at the outlet grilles. Ducting should conform to NFPA 90A and meet the requirements of Underwriters Laboratory as a Class O or Class 1 duct to specification UL 181, Standard for Factory-Made Air Ducts and Duct Connectors. Metal ducting must be sealed on both the end joints and longitudinal seams to avoid duct leakage and assure proper airflows at the grilles.

**MAINTENANCE**

**Monthly:**

Inspect and clean the exhaust grilles and filters, if so equipped.

**Annually:**

To ensure the maximum efficiency of the fan unit, is recommended to clean the inside of the fan box as well as the blower wheel.

**CAUTION:**

Automatically operated device—to reduce risk of injury disconnect from the power supply before servicing.

**DISASSEMBLY**

Turn off all power to the unit. The blower

**WARNING TO REDUCE THE RISK OF FIRE, ELECTRIC SHOCK, OR INJURY TO PERSONS, OBSERVE THE FOLLOWING:**

- A. Installation Work and Electrical Wiring Must Be Done By Qualified Person(s) In Accordance With All Applicable Codes And Standards, Including Fire-Rated Construction.
- B. Sufficient air is needed for proper combustion and exhausting of gases through the flue (chimney) of fuel burning equipment to prevent back drafting. Follow the heating equipment manufacturer's guideline and safety standards such as those published by the National Fire Protection Association (NFPA), and the American Society for Heating, Refrigeration and Air Conditioning Engineers (ASHRAE), and the local code authorities.
- C. When cutting or drilling into wall or ceiling, do not damage electrical wiring and other hidden utilities.
- D. When used as exhaust fans, ducted fans must always be vented to the outdoors.

E. If this unit is to be installed over a tub or shower, it must be marked as appropriate for the application and be connected to a GFCI (Ground Fault Circuit Interrupter) - protected branch circuit.

F. NEVER place a switch where it can be reached from a tub or shower.

**ELECTRICAL**

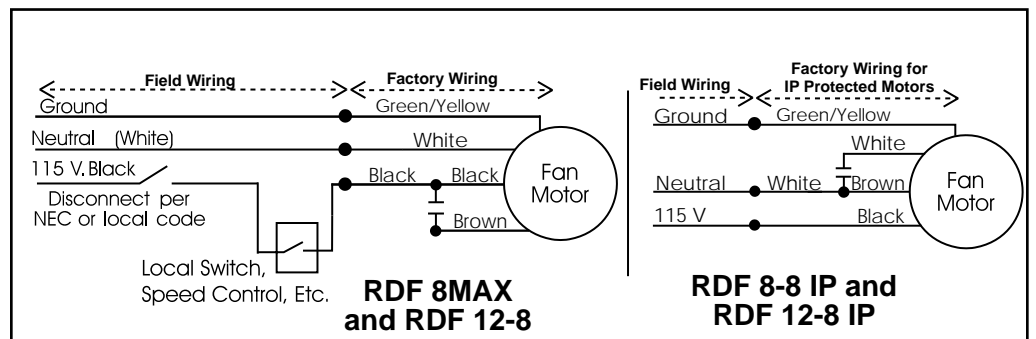
Provide disconnect switch in vicinity of fan, to permit servicing fan, in accordance with NEC and local codes.

Depending on the desired mode of operation, switches may be simple on-off switches, motor speed controls, timer switches, time delay, time of day cycle timers, dehumidistats,

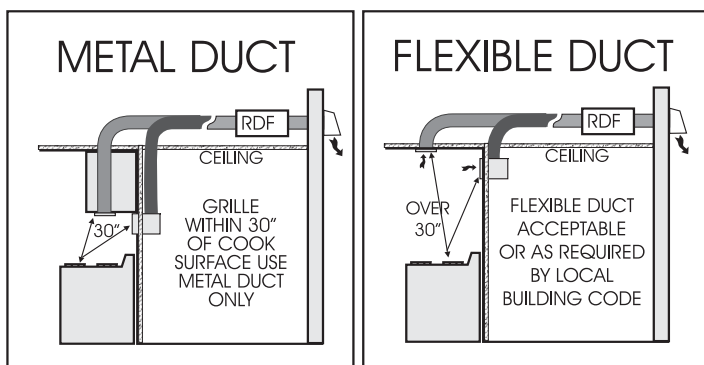
occupancy sensing controls, controllers, etc., provided they are rated for motor duty and meet the nameplate electrical ratings of the motor. (Additional application wiring diagrams are available illustrating a variety of controls for use with RDF fans by calling the factory at 1-800-255-7749.)

**ELECTRICAL DATA**

Base Model	Volts	Max Amps	Max Watts	RPM
RDF 8-8IP	115	0.19	21	2500
RDF 8-8MAX	115	0.29	34	3135
RDF 12-8IP	115	0.34	41	2200
RDF 12-8	115	0.53	59	2960



**For installations in which the fan is connected to a range hood, or if an exhaust grille connected to the fan is located near the cooking surface as shown below, be sure to observe the following safety warnings:**



**WARNING**  
**TO REDUCE THE RISK OF FIRE, USE ONLY GALVANIZED STEEL DUCTWORK WHERE REQUIRED TO USE METAL DUCT.**

**(Note: If the fan is not connected to a range hood or a grille in the vicinity of the cooking surface, other approved ducting may be used as described in "Ducting" section of basic instructions.)**

**WARNING**

**TO REDUCE THE RISK OF A RANGE TOP GREASE FIRE:**

- A. Never leave surface units unattended at high settings. Boilovers cause smoking and greasy spillovers that may ignite. Heat oils slowly on low or medium settings.
- B. Always turn hood ON when cooking at high heat or flambeing food (i.e. Crepe Suzette, Cherries Jubilee, Peppercorn Beef Flambe).
- C. Clean ventilating fans frequently. Grease should not be allowed to accumulate on fan or filter.
- D. Use proper pan size. Always use cookware appropriate for the size of the surface element.

**WARNING**

**TO REDUCE THE RISK OF INJURY TO PERSONS IN THE EVENT OF A RANGE TOP GREASE FIRE, OBSERVE THE FOLLOWING:**

- A. SMOTHER FLAMES with a close-fitting lid, cookie sheet, or metal tray, then turn off the burner. BE CAREFUL TO PREVENT BURNS. If the flames do not go out immediately EVACUATE AND CALL THE FIRE DEPARTMENT.
- B. NEVER PICK UP A FLAMING PAN - You may be burned.
- C. DO NOT USE WATER, including wet dishcloths or towels - a violent steam explosion could result.
- D. Use an extinguisher ONLY if:
  1. You know you have a Class ABC extinguisher, and you already know how to operate it.
  2. The fire is small and contained in the area where it started.
  3. The fire department is being called.
  4. You can fight the fire with your back to an exit.

\*Based on "Kitchen Firesafety Tips" published by NFPA.

may be inspected and cleaned by removing the two screws from the hinged access panel. The blower assembly can now be swung open for cleaning the wheel.

**DISCLAIMER:**

**IT IS THE RESPONSIBILITY OF THE CONTRACTOR/INSTALLER TO DETERMINE THE SUITABILITY OF THIS EQUIPMENT WITH RESPECT TO THE POTENTIAL FOR BACK DRAFTING NATURALLY VENTED FLUE DEVICES AND/OR AFFECTING RADON ENTRY.**

**IMPACT OF EXHAUST FANS:**

In especially tight homes heated with naturally vented appliances, such as gas, oil or wood-fired furnaces, boilers, stoves or fireplaces, the exhaust system may produce sufficient negative pressure indoors to induce the backdrafting of flue gases. This is a common, though intermittent occurrence, with conventional exhaust systems, such as vented kitchen range hoods, clothes dryers, bath fans, etc. In the case of continuous exhaust,

**BACKDRAFTING AND VENTILATION EQUIPMENT**

even though often at lower flow rates, the potential for backdrafting the flue of these appliances does exist, and represents a dangerous situation.

The International Fuel Gas Code, Appendix D, - ([http://www2.iccsafe.org/states/Seattle/seattle\\_fuelgas/PDFs\\_fuelgas/Appendix%20D.pdf](http://www2.iccsafe.org/states/Seattle/seattle_fuelgas/PDFs_fuelgas/Appendix%20D.pdf)) provides a Recommended Procedure for Safety Inspection of an Existing Appliance Installation.

This procedure should be followed to determine the presence of adequate combustion air, while all exhaust fans are operating at maximum speed, and all doors and windows are closed.

In the event that backdrafting occurs, steps must be taken to provide sufficient combustion air to the furnace or boiler, following the guidelines of the National Fuel Gas Code and all state and local codes.

**MECHANICAL SUPPLY FANS:**

Mechanical supply of outdoor air tends to reduce the potential and frequency of

backdraft by reducing the contributing negative pressures. However, because of a multitude of factors, including the wide range of exhausting appliances that may be present, effects of wind and building shape, presence of multiple chimneys, building leakage and use of operable windows, no one can assure elimination of backdraft conditions so long as atmospherically vented combustion equipment is present in the home.

American ALDES Ventilation Corporation accepts no liability for backdraft conditions resulting from negative pressures. Nor does American ALDES make representation that blending supply ventilators are adequate to prevent such occurrences.

**SEE THE THREE (3) YEAR WARRANTY INFORMATION EXPLAINED ON THE BACK PAGE.**

**NOTE: THIS WARRANTY SUPERSEDES ALL PRIOR WARRANTIES**

## REPLACEMENT PARTS LIST (BASE MODELS)

Model	Motor Part No	Impeller Dimensions (mm)	Capacitor Part No. Cap	
RDF 8-8IP*	86 561	133 x 42	86 172	4uF
RDF 8-8 MAX	86 561	133 x 45	86 172	4uF
RDF 12-8IP*	86 562	180 x 35	86 174	10uF
RDF 12-8	86 562	180 x 35	86 170	5uF

\*Designates Impedance Protection, with alternate wiring of capacitor across aux. winding of motor.

### THREE (3) YEAR WARRANTY

THIS WARRANTY SUPERSEDES ALL PRIOR WARRANTIES

**FOR FACTORY RETURN YOU MUST:**

- 1) Have a Return Materials Authorization (RMA) number. This number may be obtained by calling:

**AMERICAN ALDES VENTILATION CORPORATION**  
**PHONE: 1-800 255-7749.**

Please have the Bill of Sale available.

- 2) The RMA number must be clearly displayed on the outside of the carton, or delivery will be refused.
- 3) All product being returned must be shipped prepaid and be accompanied with a copy of the Bill of Sale.
- 4) Product will be replaced/repared and shipped back to buyer. No credits will be issued.

**DURING THE FIRST THIRTY (30) DAYS:**

**AMERICAN ALDES VENTILATION CORPORATION** will replace any product which has a factory defect in workmanship or material. Product may be returned to either the point of purchase or the AMERICAN ALDES factory, together with Bill of Sale, for an immediate replacement.

**DURING THE FIRST THREE (3) YEARS (excluding the above 30 day period):**

**AMERICAN ALDES VENTILATION CORPORATION** will replace any product which has a factory defect in workmanship or material. Product must be returned to the AMERICAN ALDES factory, together with the Bill of Sale, and identified with an RMA number.

**WARRANTY DOES NOT APPLY TO THE FOLLOWING:**

- Damages from shipping, either concealed or visible. Claim must be filed with the carrier.
- Damages resulting from improper wiring or installation.
- Damages caused by acts of nature, or resulting from improper consumer procedures such as:
  - Improper Maintenance
  - Misuse, abuse, abnormal use, or accident
  - Incorrect electrical voltage or current
  - Removal or alterations made on the AMERICAN ALDES VENTILATION CORPORATION label control number or date of manufacture
- Any other warranty, expressed, written or implied, and to any consequential or incidental damages, loss of property, revenues, or profit, or costs of removal, installation or reinstallation, for any breach of warranty.

**WARRANTY VALIDATION**

The end user must keep a copy of the Bill of Sale to verify purchase date.

**LIMITATIONS OF WARRANTY AND LIABILITY**

This warranty does not apply to any AMERICAN ALDES product or part which has failed as a result of faulty installation or abuse, incorrect electrical connections or alterations made by others, or use under abnormal operating conditions or misapplication of the product or parts. We will not approve for payment any repair not made by us or our authorized agent without prior written consent. The foregoing shall constitute our sole and exclusive warranty and our sole and exclusive liability, and is in lieu of any other warranties, whether written, oral, implied or statutory. There are no warranties which extend beyond the description on the page hereof. In no event, whether as a result of breach of contract, or warranty or alleged negligence, defect, incorrect advice or other causes, shall AMERICAN ALDES be liable for special or consequential damages, including but not limited to, loss of profits or revenue, loss of use of equipment or any other associated equipment, cost of substitute equipment, facilities or services, downtime costs, or claims of customers of purchases for such damages. AMERICAN ALDES neither assumes or authorizes any person to assume for it any other liability in connection with the sale of its products or parts. Some jurisdictions do not allow the exclusion or limitation of incidental or consequential damages, so the above limitations and exclusions may not apply to you.



4521 19th Street Court E., Suite 104, Bradenton, FL 34203 USA  
 P: 941-351- 3441 - F: 941-351- 3442  
 www.americanaldes.com ~ E: info@aldes-us.com



**READ AND SAVE THESE INSTRUCTIONS**

**CAUTION**

For General Ventilating Use Only. Do Not Use to Exhaust Hazardous or Explosive Materials and Vapors.

**CAUTION**

TO REDUCE THE RISK OF FIRE AND ELECTRIC SHOCK, INSTALL THIS REGISTER ONLY WITH REMOTE EXHAUST FAN MODELS RATED MAXIMUM 10A, 1/2 HP.

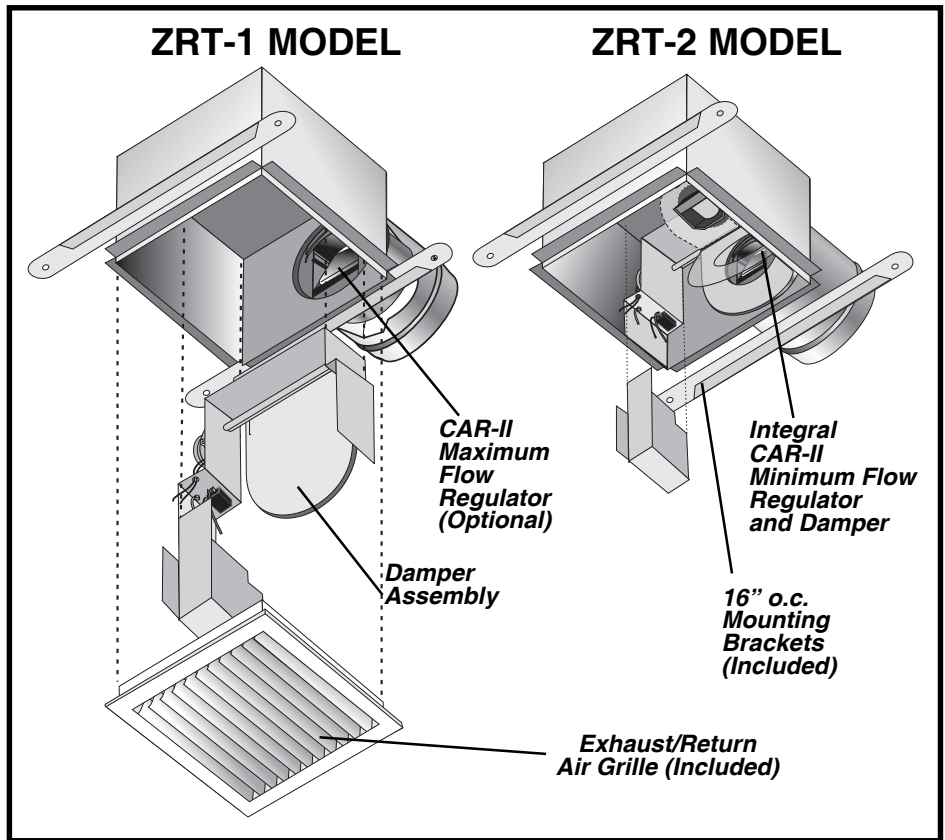
**WARNING**

TO REDUCE THE RISK OF FIRE, ELECTRIC SHOCK, OR INJURY TO PERSONS, OBSERVE THE FOLLOWING:

- A. Use this unit only in the manner intended by the manufacturer. If you have any questions, contact the manufacturer.
- B. Before servicing or cleaning unit, switch power off at service panel and lock service panel to prevent power from being switched on accidentally. When the service disconnecting means cannot be locked, securely fasten a prominent warning device, such as a tag, to the service panel.

In addition to the following manufacturer's instructions, it is necessary to comply with federal, state, and local government codes. Your purchase of this American ALDES ventilation system represents an investment in the health and comfort of the occupants, as well as an investment in the protection of the building from the damaging effects of excessive indoor humidity.

**System design :** Satisfactory performance of a central exhaust ventilation system requires the proper integration of all the components, compatible exhaust grilles, and wall/roof caps, proper duct design for friction losses, consideration of acoustic and vibration properties of the fan and its mounting, acoustic properties of the exhaust grilles, consideration of the mode of operation, whether continuous, or automatically controlled by timer, dehumidistat, occupancy sensor, etc., installation in a heated or unheated space, with consideration for the



potential of condensation in the ducting or fan housing.

**Inspect the carton** upon receipt to insure the terminal has not been damaged in transit. If damaged, it is the responsibility of the recipient to file a damage claim with the carrier. American ALDES Ventilation Corporation is not responsible for damage incurred during shipment.

**Handle the unit with care** to prevent damage to the housing and other components. Store the unit indoors if possible. If outdoor storage is required, protection against moisture and dirt is necessary.

**DESCRIPTION**

**General:** The ZRT series zone control exhaust terminals by American ALDES are designed to introduce flexibility and dynamic control of central ventilation systems. Used

in both large and small systems, the ZRT controls the ventilation where it is required without the need for individual fans. Each ZRT is a combination grille, register box, control damper and optional flow regulator(s). This unique combination provides up to four different control schemes without the need for expensive pneumatic, electronic, or DDC control systems.

By replacing static grilles in large central exhaust systems, the ZRT-1 model provides on-off control for on-demand ventilation. This allows central fan downsizing and promotes energy savings by minimizing necessary fan horsepower and ventilation induced heat and cooling loads on the building. The optional model CAR-II constant airflow regulator can be installed in the ZRT-1's extended duct collar to place a maximum flow limit on each terminal. The automatic operation of the CAR-II will prevent noise and excessive

energy consumption caused by over-ventilation, as well as fluctuations in airflow rates as total system pressure varies.

The **ZRT-2** model can also be used for combination low-flow indoor air quality ventilation and on-demand high-flow spot ventilation using the same central fan system. This is achieved by integrating a CAR-II minimum airflow controller directly into the damper subassembly. With the damper completely closed, the factory calibrated CAR-II will still allow steady low continuous ventilation during fan operation (consult the CAR-II submittal sheet for sizing and specifying information). Even as other **ZRT** terminals are opened for on-demand control of spot ventilation, the closed **ZRT-2s** will maintain the specified low continuous rate through the CAR-II minimum flow control. By opening the **ZRT-2's** control damper, the low-flow regulator is removed from the air stream, which allows either controlled (optional using 2nd CAR-II) or full maximum boost ventilation.

The **ZRT** series terminals can themselves activate fans used in smaller central exhaust ventilation systems. Through the use of an integral damper end-switch, the **ZRT** can trigger the remote fan to start. This provides the distinct advantage of allowing the fan to only ventilate specific spaces when called upon, again without the need for separate fans in each space. This is especially important in residential bath exhaust applications using popular in-line and multi-port fans, where extremely low noise and single exterior vent penetrations are desired.

### MOUNTING

The **ZRT** zone register terminals are available with mounting brackets to accommodate new or existing construction. Spanner brackets that allow mounting to joists up to 16" on-center are provided, and should be secured using the screws provided (See figure 1). Install additional blocking, or use single joist bracket if spacing is greater than 16" on-center. For installation in ceilings where drywall is already installed, use single

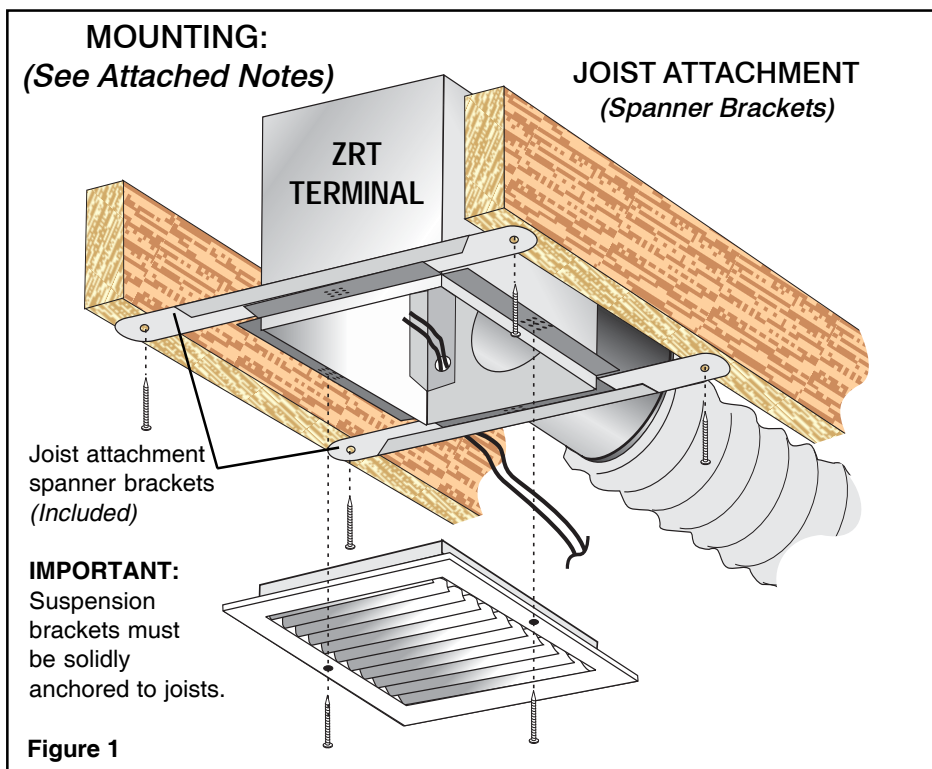


Figure 1

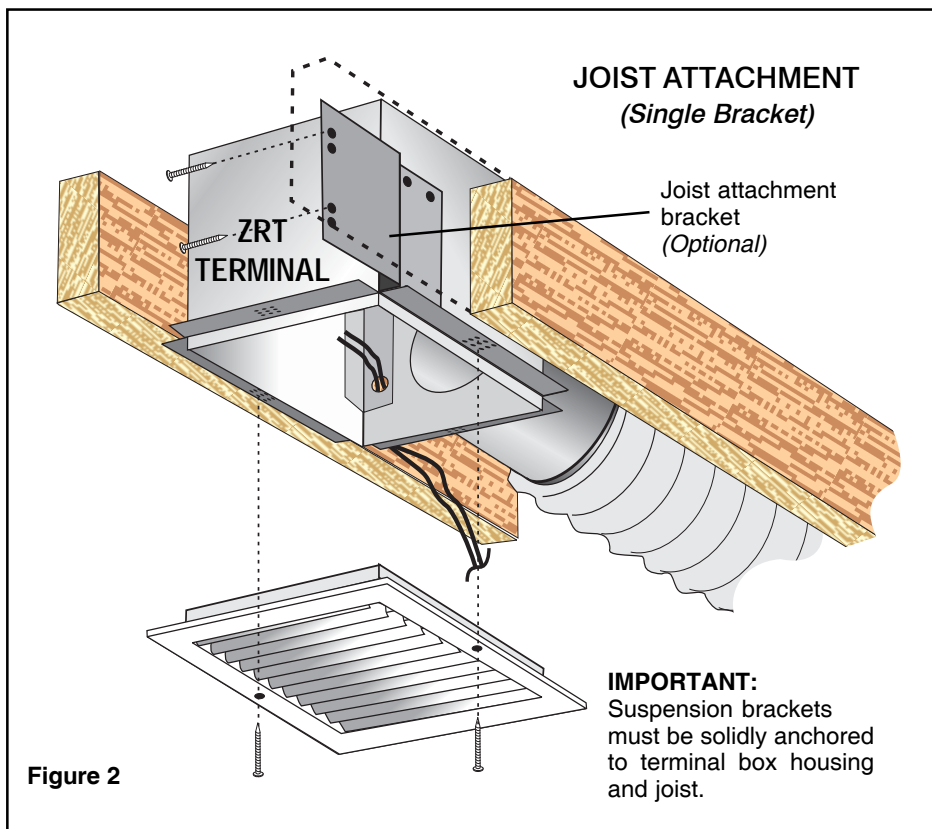


Figure 2

joist bracket and securely attach to **ZRT** housing and joist using screws provided (see figure 2). The joist bracket should be positioned on the terminal at the correct depth.

### MAINTENANCE

**Monthly:** Clean the exhaust grilles and filters, if so equipped.

***CAUTION:***  
***Automatically operated device—to reduce risk of injury disconnect from the power supply before servicing.***

## DISCLAIMER

IT IS THE RESPONSIBILITY OF THE CONTRACTOR/INSTALLER TO DETERMINE THE SUITABILITY OF THIS EQUIPMENT WITH RESPECT TO THE POTENTIAL FOR BACK DRAFTING NATURALLY VENTED FLUE DEVICES AND/OR AFFECTING RADON ENTRY.

## WARRANTY

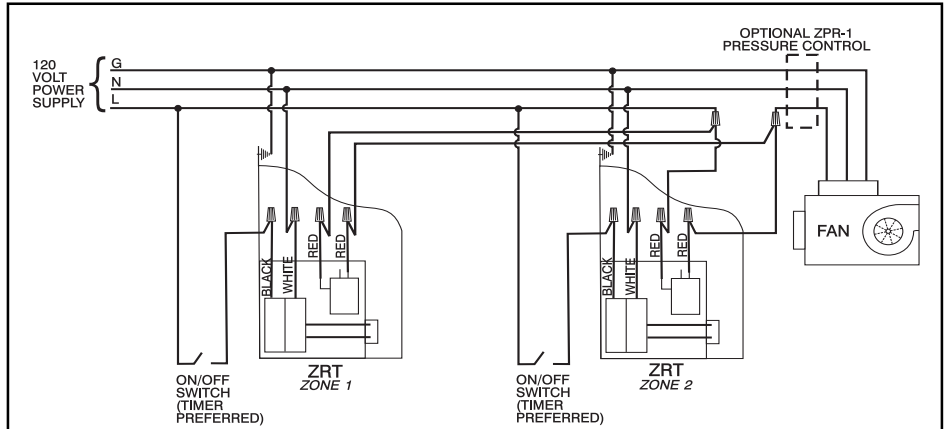
American ALDES Ventilation Corp. warrants the ZRT zone register terminal under normal use against defects in material and workmanship for three years from date of purchase. American ALDES Ventilation Corp. will, at its option, repair or replace any defective component without charge providing the product is promptly returned, prepaid to American ALDES Ventilation. This warranty is void if any unauthorized alterations or repair are made to any component part. American ALDES Ventilation Corp. disclaims and excludes any liability for implied warranties or for accidental or consequential damages wherever permitted by law. This warranty gives you specific legal rights and you may also have other rights, which vary from state to state. For warranty service or information, please contact customer service at American ALDES Ventilation Corp.

## WIRING

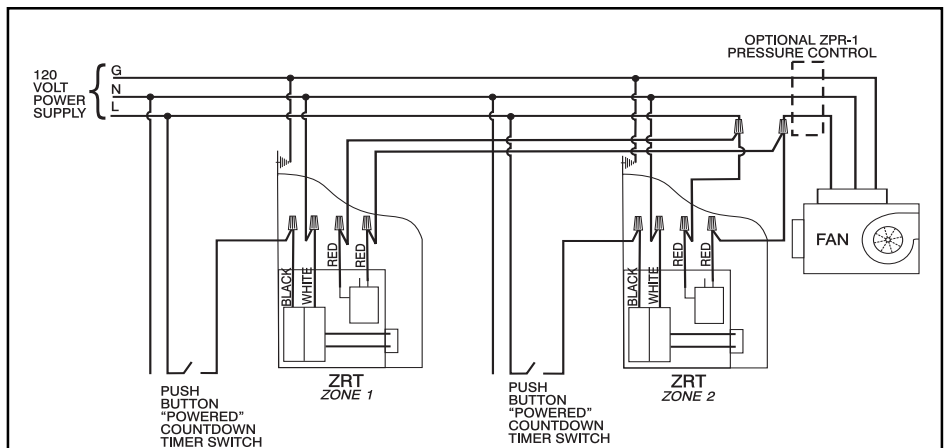
The ZRT zone register terminals are available with 120V or 24V actuator motors. 120V wiring options are shown in figures 3-5, and 24V wiring options using the ZTC zone terminal low voltage control center are shown in figures 6 and 7.

**Note:** ZRT's are approved for use over a tub or shower, the most efficient method of removing humidity from the bathroom.

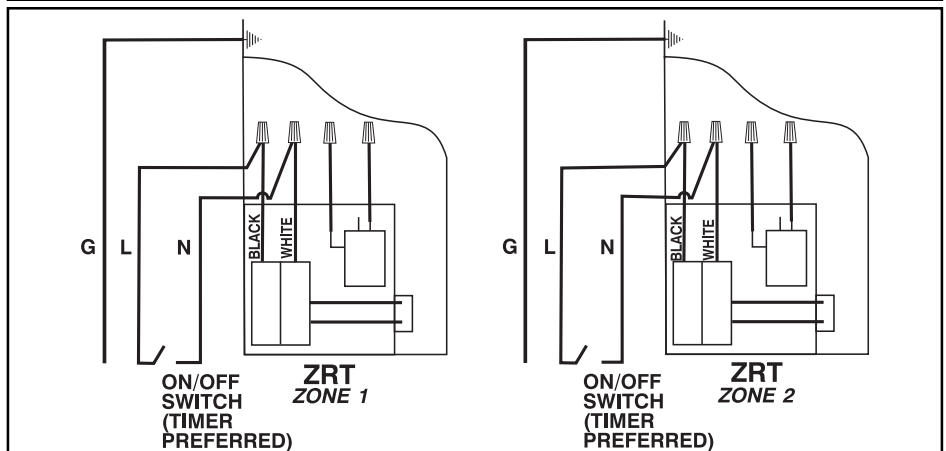
**CAUTION:** Acceptable for use over tub or shower when installed in a GFCI protected circuit. If wired directly to the fan or ZRT's, a single Ground Fault Protector on the 120V common power supply must be used to protect all devices on the same circuit.



**Figure 3 — Intermittent fan operation using 120VAC power supply to ZRT-1 terminals.** SPST convenience switches such as manually operated, mechanical timers, or dehumidistats may be used to control each ZRT and fan in this configuration.

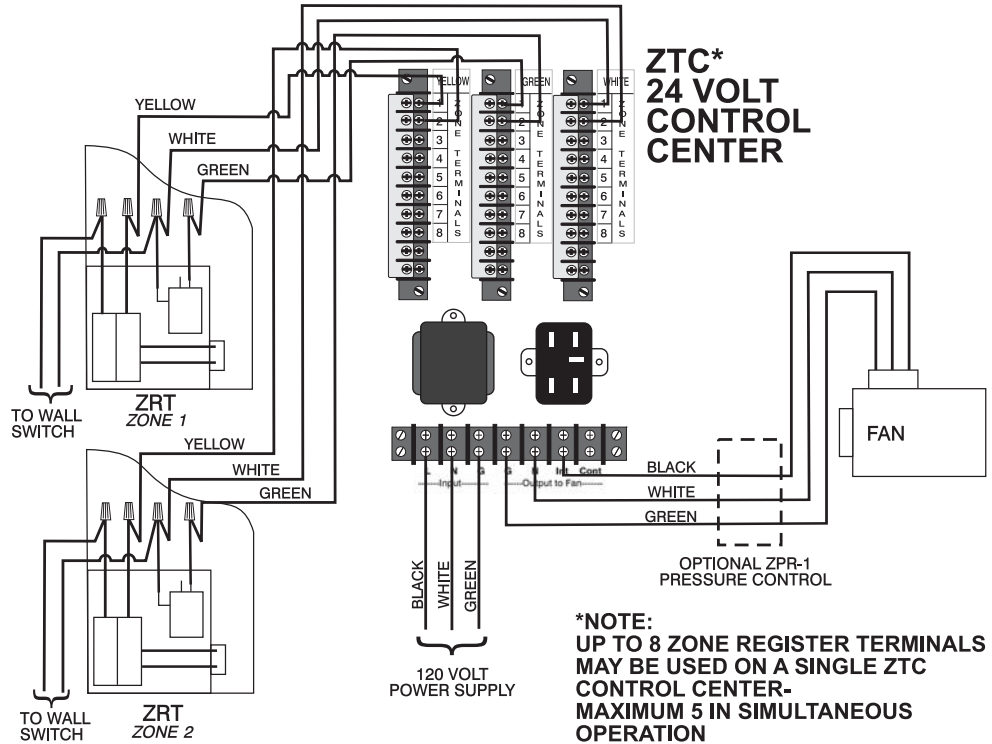


**Figure 4 — Intermittent fan operation using 120VAC power supply to ZRT-1 terminals.** SPST convenience switches such as push button timers or motion sensors may be used to control each ZRT and fan in this configuration.

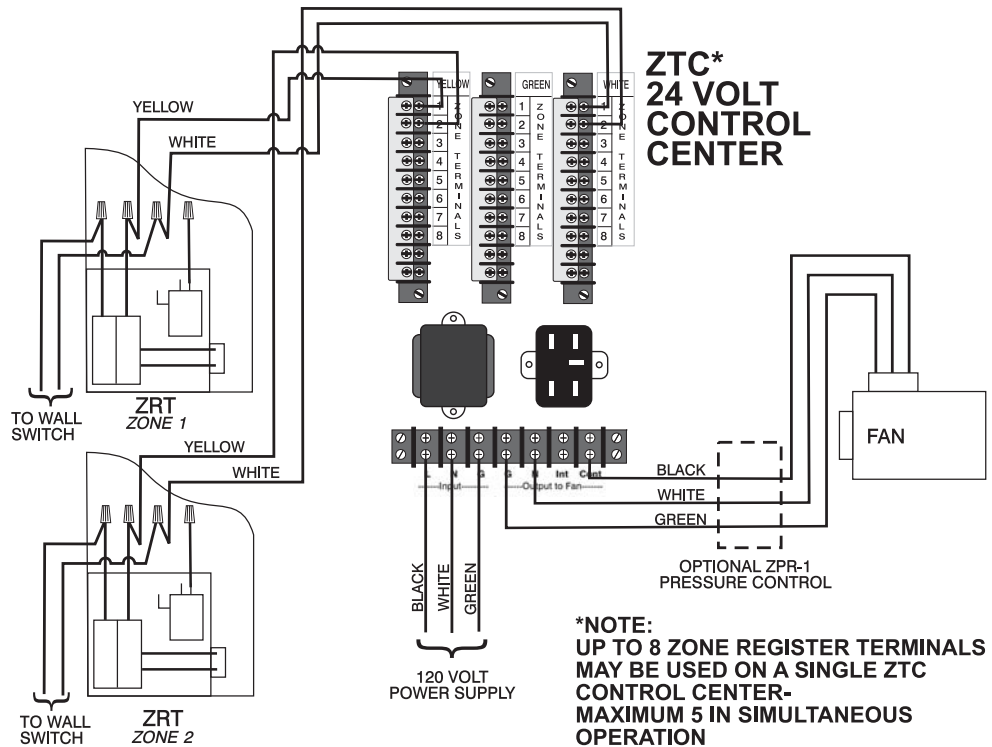


**Figure 5 — Continuous fan operation using 120VAC power supply to ZRT-2 terminals.** The fan and ZRT terminals may be wired independently.

**Figure 6 — Intermittent fan operation using 24v ZTC zone terminal control center and ZRT-1 terminals.** SPST convenience switches such as manually operated, mechanical timers, or dehumidistats may be used to control each ZRT and fan in this configuration. The fan is controlled by the ZTC.



**Figure 7 — Continuous fan operation using 24v ZTC zone terminal control center and ZRT-2 terminals.** SPST convenience switches such as manually operated, mechanical timers, or dehumidistats may be used to control each ZRT in this configuration. The fan may be wired to the ZTC or independently.



**AMERICAN**  
**aldes**  
VENTILATION CORPORATION

4521 19th Street Court E., Suite 104  
Bradenton, FL 34203, USA  
TEL:941-351-3441 ~ FAX:941-351-3442  
www.americanaldes.com - www.ventzone.com  
e-mail: info@aldes-us.com

**IAQ**  
VENTILATION  
**HOTLINE**  
**800-255-7749**

zrt\_iom\_0909