

**General:** The model CAR-II Constant Airflow Regulator is a modulating orifice that automatically regulates airflows in duct systems to constant levels. The passive control element responds to duct pressure, and requires no electric or pneumatic sensors or controls.

The CAR-II compensates for changes in duct pressure caused by thermal stack effect, building pressure, dust clogging of filters, etc. The CAR-II also provides a low cost solution to balancing forced air systems for heating, air conditioning and ventilation, eliminating the need for on-site balancing. The CAR-II will regulate airflow in supply, return or exhaust duct systems.

The active control element of the CAR-II is a unique aerofoil. Using the Bernoulli effect, the active control element of the CAR-II is a unique aero-wing damper that lifts in response to increasing static pressure. This operation regulates the free-area opening through the control, resulting in maintenance of velocity and specific airflow set points. Each CAR-II is designed and produced for control of air in temperatures ranging from -25° to 140° F (-32° to 60° C.)

**Construction:** The round CAR-II is constructed of a UL94V-0 ABS plastic, and is UL 2043 safety listed and labeled for flame and smoke generation. The assembly is sized to fit inside standard rigid round ducting, as well as fittings such as takeoffs, tees, etc. A lip or flex-type ring seal gasket around the circumference ensures a tight, no-leak fit.

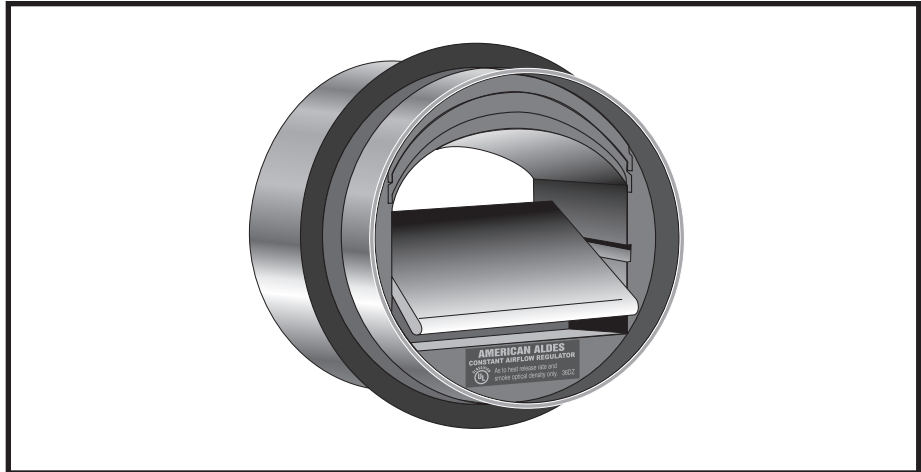

**Dimensional Data**

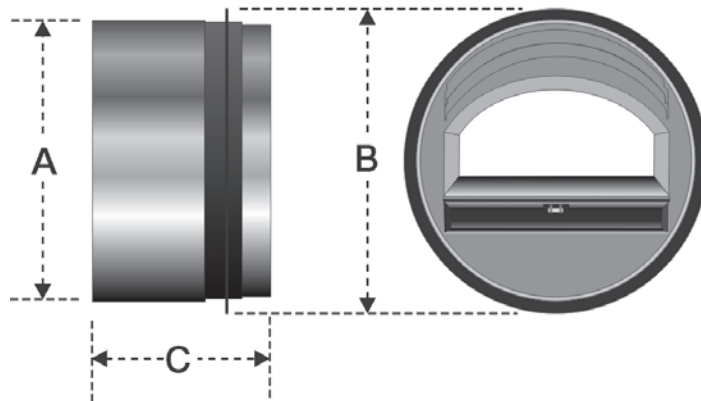

Duct	CAR-II	A	B	C
4"	4	3.8	4.1	2.3
5"	5	4.8	5.1	3.5
6"	6	5.8	6.1	3.5
8"	8	7.6	8.1	3.5
10"	10	9.7	10.1	3.7

All sizes shown are in inches

**Performance:** The CAR-II airflow regulators control airflow accurately to within 10% of rated flow (15% for units 50 cfm or less), throughout the target operating pressure range of 0.2 to 0.8 in. w.g. (50 to 200 Pa). Each CAR-II is factory tested and calibrated to the rated set point before shipping. On-site field adjustment of airflow set points can be made for supply air applications (contact factory). Each diameter of CAR-II regulator is available in multiple factory calibrated set points (see performance curves).

**Maintenance:** The CAR-II needs no maintenance when used in normal conditions. There is no risk of dust deposit or obstruction because the CAR-II has no airways subject to clogging. If the intended application includes air heavily loaded with grease or dust, a fitting with an access panel or door, such as that used for flame dampers, should be provided.

**Warranty:** Guaranteed for 5 years, from date of shipment, against all defects in material or workmanship, provided that the material has been installed and utilized under normal conditions. This warranty is limited to the repair or replacement of the material.

## Typical Applications

- **Supply and exhaust air of offices.**
- **Balancing exhaust and supply airflows in high-rise building duct risers.**
- **Bathroom exhaust in nursing homes, hotels, motels, dormitories, apartment buildings, offices, etc.**
- **Clean room air supply balancing for ceiling filter modules. Maintains constant airflow even as filter resistance increases.**
- **Regulation of makeup air.**
- **Balancing supply airflow from packaged roof top A/C units.**
- **Balancing supply and exhaust of heat recovery ventilation systems**
- **Regulating outdoor air injection from central supply fan into individual room fan coil units, or heat pumps.**
- **Balancing airflows on series fan powered terminal unit systems.**
- **Supply air to sleeping quarters in military facilities, submarines, etc.**
- **Controlling conditioned air to sealed crawlspaces.**

## Typical Specification

Model CAR-II Constant Airflow Regulators by **American ALDES Ventilation Corporation**, Sarasota, Florida, shall solely operate on duct pressure and require no external power supply. Each regulator shall be preset and factory calibrated requiring no field adjustment to the airflows as indicated on the schedule, and shall be rated for use in air temperatures ranging from -25° to 140° F (-32° to 60° C.)

Constant airflow regulators shall be capable of maintaining constant airflow within +/- 10% of scheduled flow rates (15% for units 50 cfm or less), within the operating range of 0.2 to 0.8 in. w.g. differential pressure, or 0.6 to 2.4 in. w.g. on high-pressure models. Regulators shall be provided as an assembly consisting of a 94V-0 UL ABS plastic body housed within a round sleeve for mounting in round duct. Each round sleeve must be fitted with a lip gasket to assure perimeter air tightness with the interior surface of the duct. All regulators must be listed per UL2043 and carry the UL mark indicating compliance. All Constant Airflow Regulators will require no maintenance and must be warranted for a period of no less than five years. Constant Airflow Regulators shall be installed in tight ducting systems in accordance with all applicable codes and manufacturer's instructions.

# How the CAR-II Works

Constant airflow is achieved by controlling the free area through the device. At minimum static pressure, the aero-wing is parallel to the air stream. As the static pressure increases, the aero-wing lifts, thereby reducing the amount of free area through the regulator. At the same time, the higher static pressure increases the air velocity resulting in **CONSTANT AIRFLOW**. This occurs regardless of pressure differences in the range of 0.2 to 0.8 in. w.g. (50 to 200 Pa). The air velocity in the duct is in the range of 60 to 700 ft/min. (0.3 to 3.5 m/s).

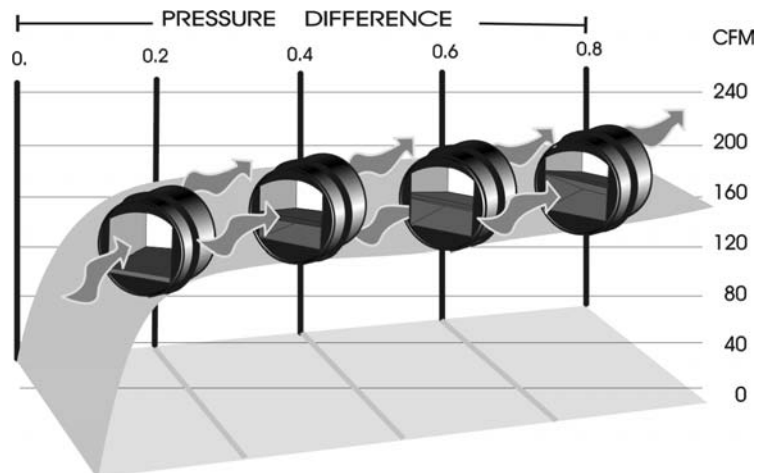

(6" EXAMPLE SHOWN)

# CAR-II Airflow Performance Data

Performance charts reflect airflow measurements taken at 68° (20° C) at 1 atmosphere pressure. CAR-II's designed for system pressures above 0.8 in. w.g. are also available. Consult the factory for information.

## 4" DIA. (100mm) Regulating Element

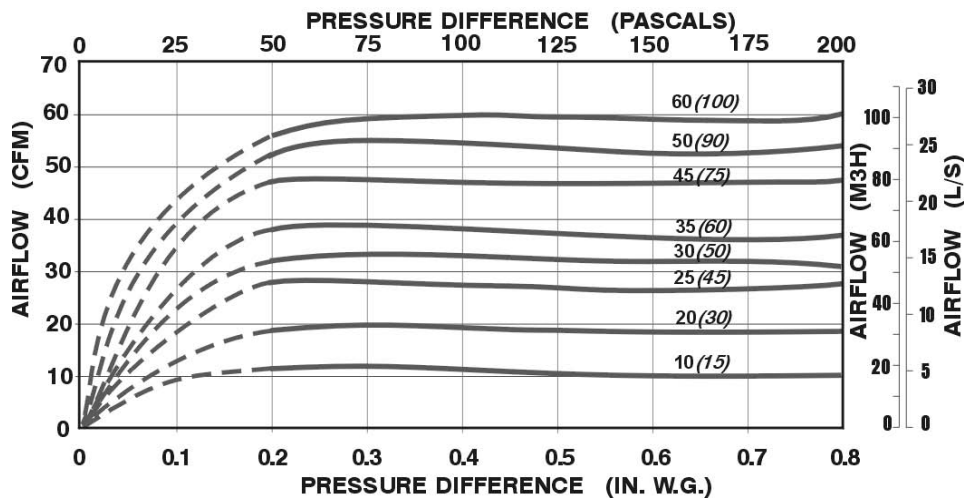

PART #	AIRFLOW
#18 111	10 cfm ( 15 m3/h)
#18 112	20 cfm ( 30 m3/h)
#18 113	25 cfm ( 45 m3/h)
#18 114	30 cfm ( 50 m3/h)
#18 115	35 cfm ( 60 m3/h)
#18 116	45 cfm ( 75 m3/h)
#18 117	50 cfm ( 90 m3/h)
#18 118	60 cfm (100 m3/h)

## 5" DIA. (125mm) Regulating Element

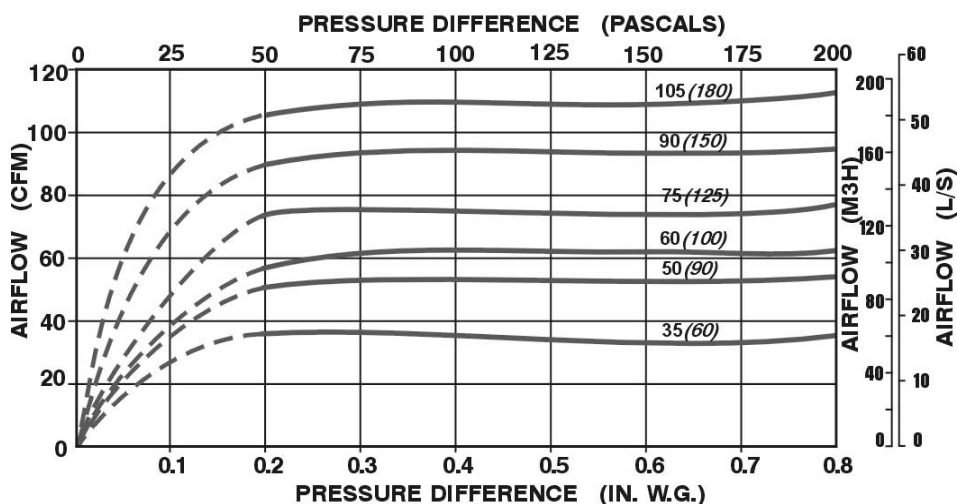

PART #	AIRFLOW
#18 121	35 cfm ( 60 m3/h)
#18 122	50 cfm ( 90 m3/h)
#18 123	60 cfm (100 m3/h)
#18 124	75 cfm (125 m3/h)
#18 125	90 cfm (150 m3/h)
#18 126	105 cfm (180 m3/h)

### 6" DIA. (150mm) Regulating Element

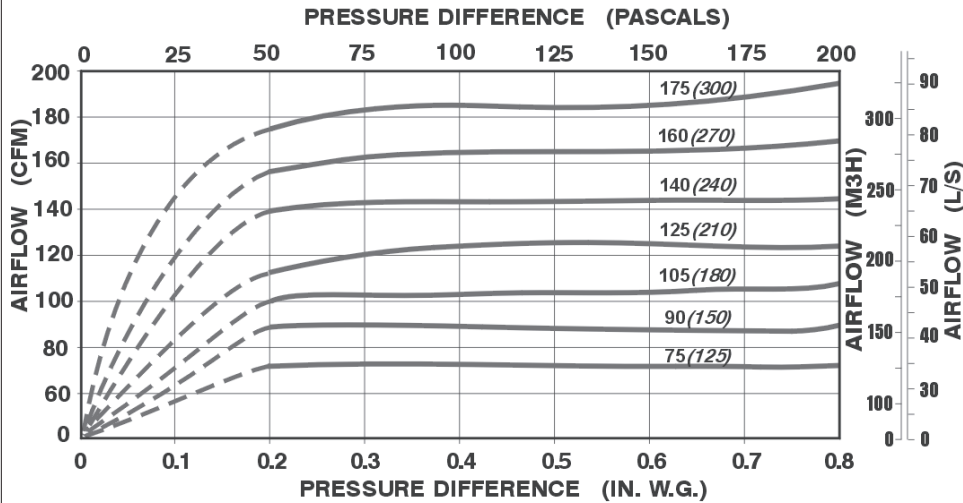

PART #	AIRFLOW
#18 131	75 cfm (125 m3/h)
#18 132	90 cfm (150 m3/h)
#18 133	105 cfm (180 m3/h)
#18 134	125 cfm (210 m3/h)
#18 135	140 cfm (240 m3/h)
#18 136	160 cfm (270 m3/h)
#18 137	175 cfm (300 m3/h)

### 8" DIA. (200mm) Regulating Element

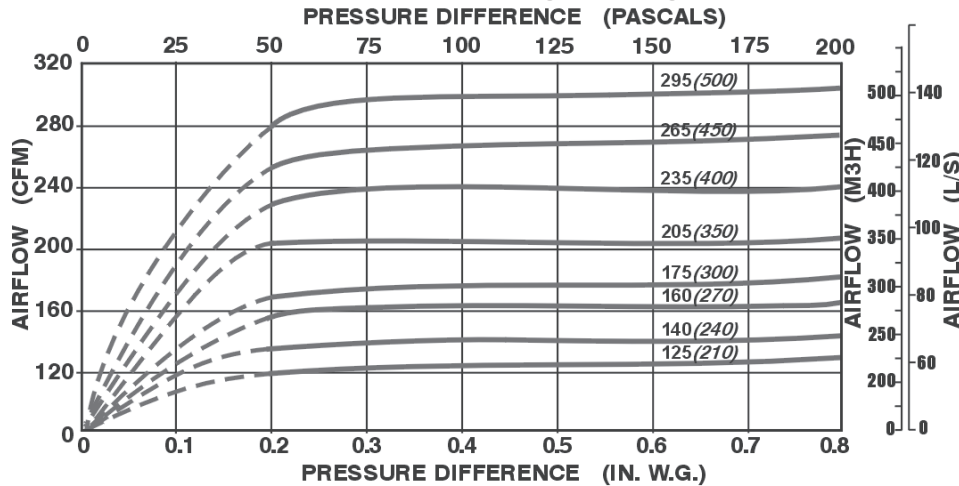

PART #	AIRFLOW
#18 141	125 cfm (210 m3/h)
#18 142	140 cfm (240 m3/h)
#18 143	160 cfm (270 m3/h)
#18 144	175 cfm (300 m3/h)
#18 145	205 cfm (350 m3/h)
#18 146	235 cfm (400 m3/h)
#18 147	265 cfm (450 m3/h)
#18 148	295 cfm (500 m3/h)

### 10" DIA. (250mm) Regulating Element

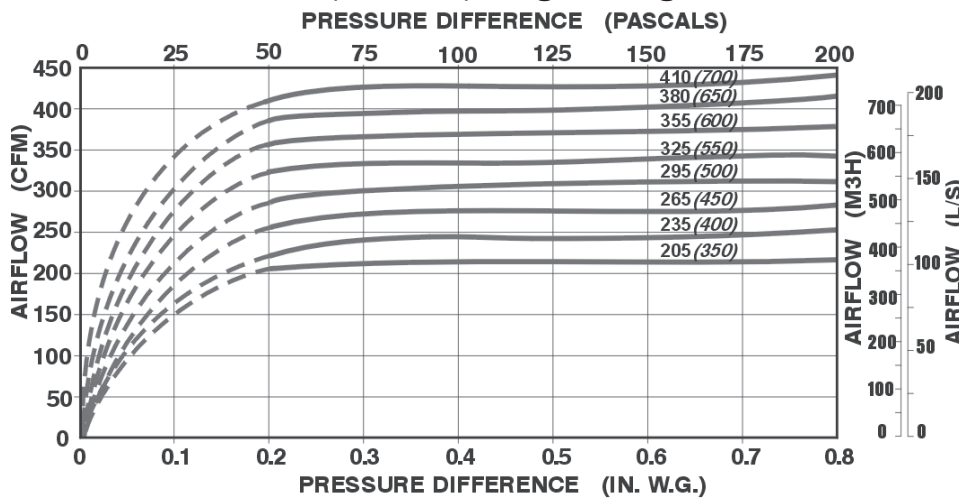

PART #	AIRFLOW
#18 151	205 cfm (350 m3/h)
#18 152	235 cfm (400 m3/h)
#18 153	265 cfm (450 m3/h)
#18 154	295 cfm (500 m3/h)
#18 155	325 cfm (550 m3/h)
#18 156	355 cfm (600 m3/h)
#18 157	380 cfm (650 m3/h)
#18 158	410 cfm (700 m3/h)



4521 19th Street Court E., Suite 104, Bradenton, FL 34203 USA  
 Telephone: 941-351-3441 | Fax: 941-351-3442  
 www.americanaldes.com | E-mail: info@aldes-us.com



car\_ii\_spec\_0810